

Installation Instructions

Short Throw Shifter

1995-1997 Eagle Talon
1995-1996 Dodge Avenger
1995-1996 Chrysler Sebring
1995-1999 Mitsubishi Eclipse
Part Number 45077

©2003, 2000 by B&M Racing and Performance Products LLC

This **B&M Short Throw Shifter** has been designed to work on most 1995-1997 Eagle Talon, 1995-1996 Dodge Avenger, 1995-1996 Chrysler Sebring, and 1995-1999 Mitsubishi Eclipse models equipped with a manual transmission. It has been engineered to greatly reduce shift throw and improve shifter feel. Check the tool list at the end of these instructions for the tools required to install your **B&M Short Throw Shifter**. Installation of the **B&M Short Throw Shifter** can be accomplished by anyone with minimal mechanical experience.

INTRODUCTION

The **B&M Short Throw Shifter** can be installed in less than an hour by carefully following the instructions. Read all instructions first to familiarize yourself with the parts and procedures. This kit contains all the parts necessary to install the shifter.

DISASSEMBLY

STEP 1. Remove the ash tray/cupholder by pulling up from both sides.
STEP 2. Using a #2 Phillips screw-

driver, remove the 2 screws under the ash tray/cupholder.

STEP 3. Using a #2 Phillips screwdriver, remove the 2 screws on the back sides of the center console storage compartment (it may be helpful to slide the seats forward).

STEP 4. Unscrew the shift knob (counterclockwise) and slide the shifter boot retainer up until it is loose.

STEP 5. Remove the stereo/climate control face plate by pulling and/or prying out gently with a small flat blade

screwdriver. Be careful not to break or scratch the control panel.

STEP 6. Using a #2 Phillips screwdriver, remove the 2 screws that are holding the center console on both sides of the stereo.

STEP 7. Remove the ash tray light by turning the light housing from the underside of the console. Carefully lift up the center console and remove the cigarette lighter by unclipping the center wire of the lighter housing on the back side of the console and unscrewing the

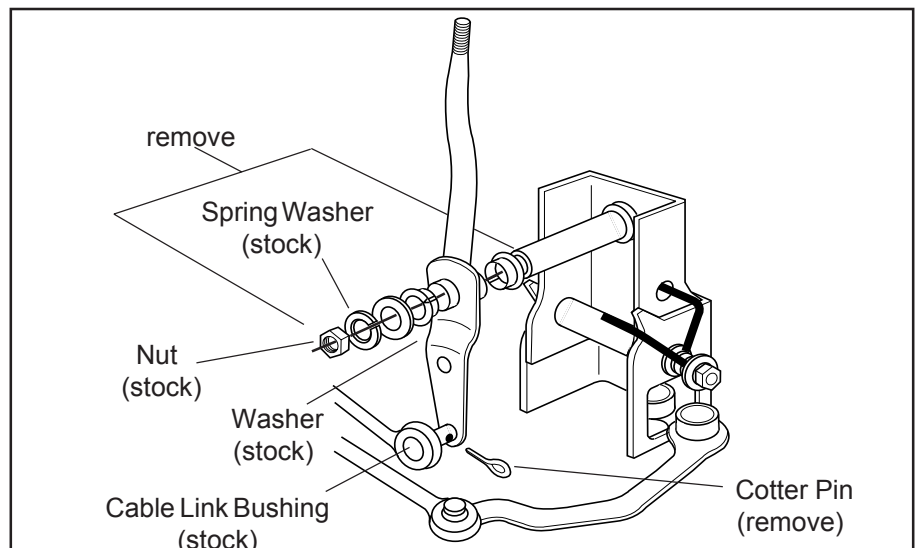

retaining ring. Then lift out the center console.

STEP 8. Using pliers, remove the cotter pin which attaches the cable link to the bottom of the shift stick.

STEP 9. Using a 12mm wrench, remove the nut which attaches the shifter to the pivot.

STEP 10. Remove the stock shifter leaving only the cable link bushing.

ASSEMBLY

STEP 11. Place a supplied nylon washer onto the Pivot Shoulder and then slide **B&M Short Throw Shifter Pivot** onto the shoulder. Make sure the bearing hole is in the up position and the square step is facing away from the shifter.

STEP 12. Insert the other supplied nylon washer into the other side of the **B&M Short Throw Shifter Pivot**, apply a drop of Loctite® on to the threads of the supplied Lock Nut and then tighten it onto the threads of the

Pivot Shoulder inside the **B&M Short Throw Shifter Pivot** pocket.

STEP 13. Decide which hole position at the bottom of the **B&M Short Throw Shifter** is suitable for your needs:

Top hole-35% throw reduction
Bottom hole-50% throw reduction
-Apply a drop of Loctite® to the threads of the supplied Shift Pin then screw it through the chosen hole in the bottom of the shifter using a 7/16" wrench.

STEP 14. Push the stock cable link bushing onto the exposed "nose" of the Shift Pin and snap the supplied e-clip into the groove to secure.

STEP 15. Slide the **B&M Short Throw Shifter** assembly onto the exposed stock pivot pin, making sure the bearing hole is in the up position and the square step is facing the passenger's side and sits flat on the stock pivot base.

STEP 16. Reinstall the stock washer, spring washer and nut. Then, tighten the nut with the 12mm wrench.

STEP 17. Test the movement of the

B&M Short Throw Shifter through all of the gears. Make sure it smoothly enters all gears without binding or interfering; and check that all the nuts and bolts are snug.

STEP 18. Re-assemble the center console in the reverse order that it was disassembled.

Parts List

- 1 B&M Short Throw Shifter
- 1 B&M Short Throw Shifter Pivot
- 1 Shift Pin
- 1 5/16"-18 Lock Nut
- 1 E-Clip (2 supplied/1 required)
- 2 Nylon Washers
- 1 Tube of Loctite®
- 1 Instruction Sheet

Tool List

- 12mm Wrench
- Small Flat Head Screwdriver
- #2 Philips Screwdriver
- 1/2" Socket and Drive
- 7/16" Wrench
- Pliers

