



# Installation Instructions

## StarShifter

Part Number 80675

©2000 by B&M Racing & Performance Products LLC

The **B&M StarShifter** can be used in vehicles equipped with most popular three speed automatic transmissions. Your **B&M StarShifter** comes equipped with a neutral safety switch, transmission brackets and levers and a five foot shift cable. Optional shifter cables in 2 ft. (#80830), 3 ft. (#80831), 4 ft. (#80832), 8 ft. (#80834), 10 ft. (#80835) and 12 ft. (#80836) are also available.

Please read the instructions and review the illustrations thoroughly before beginning the installation.

The mechanical components of this shifter are precision made and assembled at our factory. Any modification or disassembly of these parts can cause the shifter to malfunction and will void the warranty. You should disassemble only those items outlined in the instructions.

The vehicle should be about 2 feet off the ground for ease of installation. Use jack stands, wheel ramps or a vehicle lift. Make sure the vehicle is firmly supported before attempting to work on it.

**IMPORTANT:** If your vehicle is equipped with a locking steering column. Securing the column lock lever in the engine compartment in the full up position will allow the steering wheel to be locked and unlocked and the ignition key to be removed. **WARNING:** This allows the steering wheel to be locked **WHENEVER** the ignition key is turned to the "lock" position **WHILE THE VEHICLE IS MOVING, OR AT ANY OTHER TIME.** Securing the steering column lock lever in any other position will both **PREVENT** the steering wheel from locking and removal of the ignition key.

### INSTALLATION

**STEP 1.** Remove the stock shift linkage; **Column Shifters:** Remove all rods, lev-

ers or cables from the column and the transmission. Place the column shift lever in the Park position. Remove the pin holding the shift lever in the column and remove the lever assembly. If your vehicle is equipped with a locking steering column, secure the column lock lever in the full up position. **WARNING:** This allows the steering wheel to be locked and the ignition key removed **WHENEVER** the ignition key is turned to the "lock" position **WHILE THE VEHICLE IS MOVING, OR AT ANY OTHER TIME.**

**Console Shifters:** Remove the shifter mechanism from the console. Disconnect the rod or cable from the transmission. Remove the cable bracket if equipped. If there is a cable or linkage from the console shifter or the transmission to the steering column lock, it must be blocked in the Park position as described above.

**NOTE:** Shifter installation may require console modification or complete console removal depending on the space available in your vehicle.

**STEP 2.** Pull the carpet away from the floorboard where the shifter is to be mounted. If the vehicle has a bench type seat, move the seat to the full forward position. Place the shifter on the floor with the stick shifted to the rearmost position. Locate the shifter for ease and convenience of operation. (The rear mounting hole of the mechanism must be at least 1-3/4" from the front of the seat when the seat is in the full forward position.) Make sure the trigger and the T-handle clear the dash with the shifter in the Park position. Mark the position of four mounting holes on the floor.

**STEP 3.** Drill four 9/32" mounting holes where marked. Temporarily mount the shifter in place using washers as re-

quired to get it level. Mark the location for the shifter cable hole, 1-3/8" ahead of the front shifter mounting hole and 2-1/4" to the left of that hole. Drill or cut a 1-1/2" diameter cable hole in the floorboard.

**NOTE:** Some floorboards are extremely thin and will not adequately support the shifter mechanism when bolted to the floor. For those vehicles we recommend a stiffener plate for additional strength.

**STEP 4.** Install (but do not secure) the carpet back to its original position. Cut holes in the carpet for the mounting holes and the cable. **DO NOT** use a drill bit to make the holes in carpet.

**STEP 5.** Install the plastic indicator traveler and link onto the T-plate track. The bent end of the link goes through the hole in the traveler from the left side of the shifter. Install the cable on the shifter as shown in **Figure 1.** The cable attachment tab must be bolted to the outside surface of the shifter base using a 1/4" X 1/2" hex bolt, a lock washer and a nut. Put the end of indicator link on the cable pin outside of the shifter cable. Install the e-clip to secure the cable and the indicator link to the cable pin.

**STEP 6.** Place the shifter in first gear ratchet mode (stick all the way back). Position the backup light switch on the inside of the T-plate and the neutral safety switch on the outside of the T-plate with the long fingers on the switches towards the plastic traveler using the forward pair of holes in the T-plate. Assemble the backup and neutral safety switches to the shifter using two #4-40 screws, nuts and lock washers, as shown in **Figure 1.** **Beware,** over tightening the switch attachment screws will crack the switch housings. Adjust the switches so that the neutral safety switch operates in Neutral and Park only and the backup light switch op-

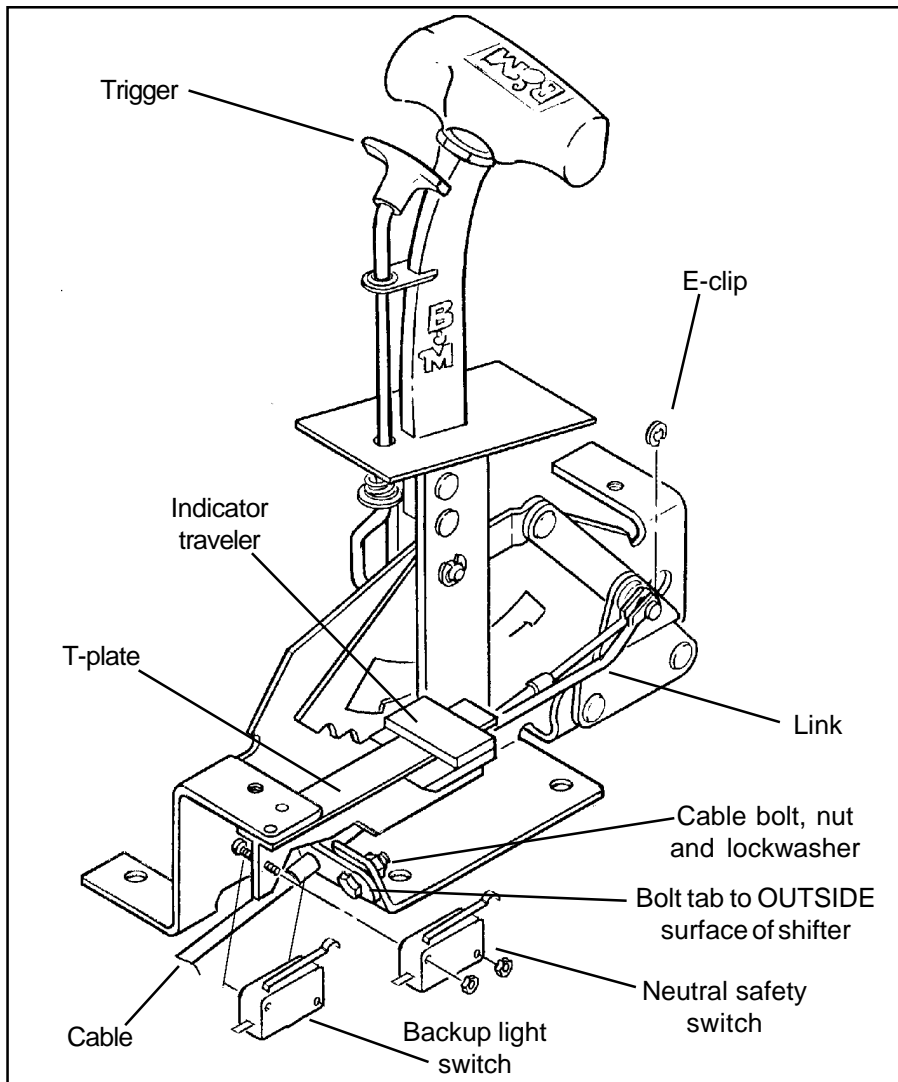

Figure 1

operates only in Reverse. Do this by loosening the screws and sliding the switches as required. Then retighten the screws.

**STEP 7.** Install the shifter mechanism into the vehicle. Slide the shifter cable through the carpet and the hole in the floor. Bolt the shifter down using four 1/4" hex bolts and nuts. If required use 1/4" washers as shims between the shifter mechanism and the floor to level the shifter. **ROUTE THE CABLE AS SHOWN IN FIGURE 2, AVOID SHARP BENDS WHICH WILL KINK AND DAMAGE THE CABLE.** Use cable clamps or tie wraps to secure the cable housing to the chassis to avoid contact with hot engine or exhaust system. Seal the cable hole shut to avoid the entry of exhaust fumes or water. For General Motors vehicles go to **Step 8**, for Ford vehicles go to **Step 13**, for Chrysler vehicles go to **Step 19**.

#### GENERAL MOTORS

**STEP 8.** If you have not already done so,

remove the stock selector lever nut and the selector lever. Discard the stock lever and the stock shifter linkage. Install the **B&M** selector lever in position using the stock selector lever nut (**See Figure 3**). Torque the nut to 23 lb.ft. The lever should move smoothly from front to rear with a positive click in each gear position.

**STEP 9.** Remove the two transmission oil pan bolts from the middle of the left side of the oil pan. Install the cable bracket in position (**See Figure 3**). The bracket must be installed with two spacers between the pan and the bracket. (If your transmission is equipped with a cast aluminum oil pan, these spacers should be omitted however the cable bracket will have to be modified). Install the two 5/16-18 x 1.00" bolts supplied and tighten to 12-13 lb.ft. Do not overtighten as this can damage the pan gasket.

**STEP 10.** Remove the two rubber boots, one large nut, and a large lockwasher from the threaded end of the shifter cable. Route the shifter cable according to **Fig-**

**ure 2.** Avoid sharp bends and route the cable away from hot engine exhaust parts. Slide the end of the cable into the cable bracket, install the lockwasher and the large nut over the end of the cable. Position the cable so the threaded portion of the cable housing is centered in the cable bracket. Tighten both large nuts to hold the cable in this position. Install the two rubber boots onto the end of the cable.

**STEP 11.** Move the transmission selector lever by hand to full rear position (Low). Operate the shifter lever to the Low gear position (all the way back). Adjust the large nuts on the cable so that the swivel will slide into the **center** hole on the selector lever. Tighten the large nuts completely. Be sure that the swivel will slide freely in and out of the hole in the selector lever. **Note: The shifter will not operate correctly unless the center hole in the shift lever is used.**

Leave the swivel out of the hole and move the selector lever to Park, all the way forward. Also move the shifter to the Park position (all the way forward). Reinsert the swivel into the **center** hole in the selector lever. Check to see that the swivel will slide freely in and out of the **center** hole in the selector lever in this position. If it does not slip in freely, adjust the swivel slightly until it will slip into the hole in the lever.

Move the shifter back to the Low gear position and check that the swivel will still slide easily in and out of the **center** hole in the selector lever. (If you do not use the **center** hole in the lever, it will be impossible to correctly adjust the cable). Operate the shifter through all the gear positions. Check to make sure the swivel will slide in and out of the **center** selector lever hole in each gear position. The shift cable is now correctly adjusted. Install the cotter key supplied with the shifter into the swivel and spread the key ends.

If you have a problem, **DO NOT FORCE THE SHIFTER**, this will damage the cable, the shifter or the transmission. Simply start at the beginning and check all your steps.

**STEP 12.** On GM vehicles, the neutral safety switch may be located on the shifter (steering column or console), or it may be a mechanical interlock in the steering column that prevents the key from turning to the Start position unless the shifter is in the Park or Neutral position. Identify the type of neutral safety system you have. If the key will not turn to the Start position unless the stock shifter is in Park or Neutral, you have a mechanical interlock type, otherwise you have a neu-

tral safety switch type. If you have a neutral safety switch, locate the switch and identify the neutral safety wires (engine will not crank unless these wires are connected together). With either type, disconnect the battery ground cable to prevent accidental shorts. If you have a neutral safety switch, disconnect and extend both wires from the GM switch to the switch on the shifter. If you have a mechanical interlock cut the wire that goes from the Start position on the ignition switch to the solenoid on the starter. This wire is usually a 10 or 12 gauge purple wire. Run wires from both ends of the cut wire to the switch on the shifter. Put slip on terminals on the ends of the lengthened wire. Crimp the terminals onto the wires using a crimping tool or pliers. Connect the wires to the **OUTER** switch on the shifter. Identify the wires for the backup lights and run them to the **INNER** switch on the shifter. Tape the terminal connections and all other connections to prevent shorts. Reconnect the battery ground cable, disconnect the coil wire and set the parking brake. Check the switch operation by attempting to start the motor in each shifter position. **The starter must crank only when the shifter is in the Park or Neutral position.** Adjust the switch if required. Reconnect the coil wire. Go to step 25.

**FORD**

**STEP 13.** If you have not already done so, remove the nut and lockwasher holding the downshift linkage onto the downshift lever shaft. The downshift lever is the

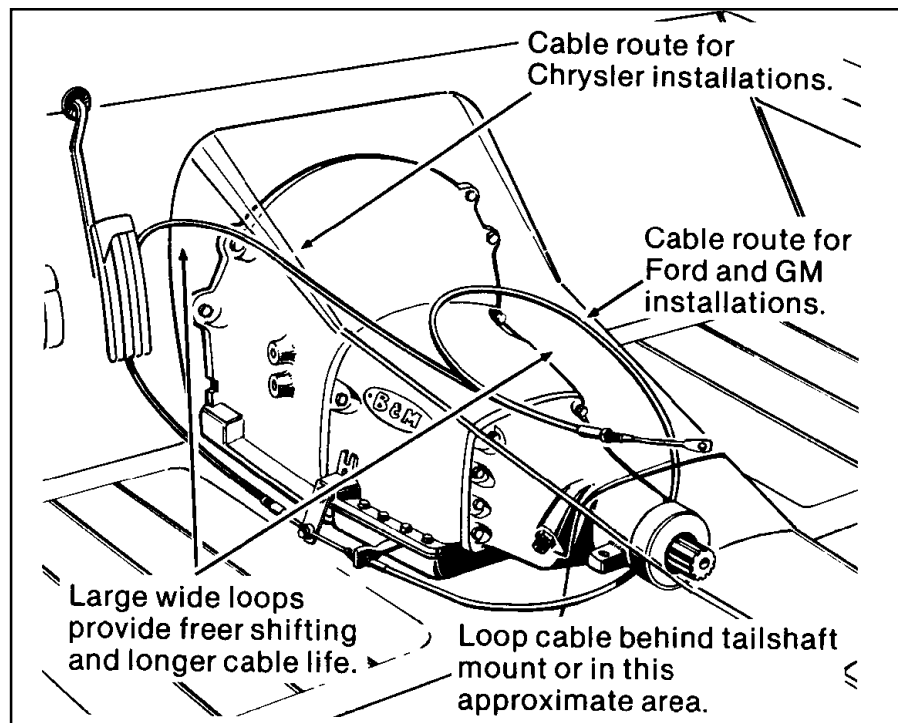
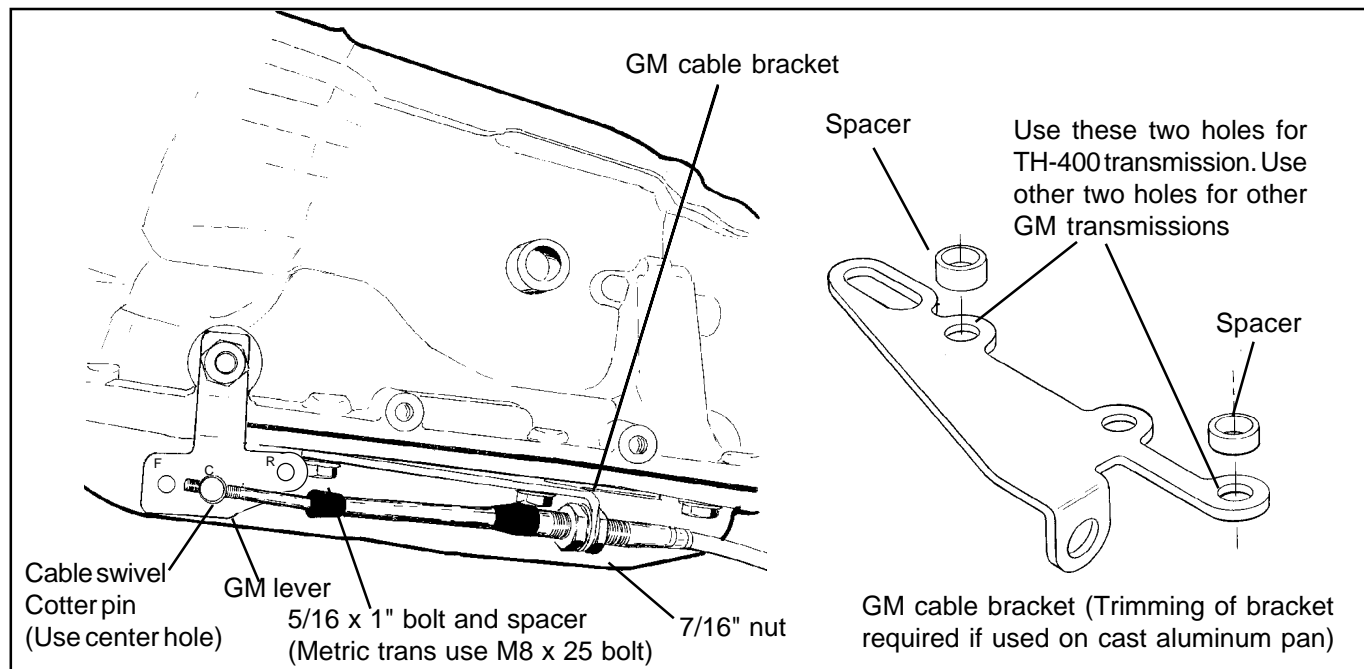

**Figure 2**

outer lever on C-4, C-5 and C-6 transmissions. Pull the lever off the shaft and allow the linkage to hang free. Remove and discard the stock shift linkage rods. Some C-6 and all (late) C-4 and C-5 transmissions have a neutral safety/back-up light switch on the transmission shift lever. If your transmission is so equipped, remove the two bolts holding the switch in place and slide it off the shift shaft. Disconnect the switch at the factory plug and discard it.

**STEP 14.** Install the **B&M** selector lever

(See Figure 4 or 5). Note: The **B&M** lever must point downward for proper operation. If the stock shift lever on your transmission points down, you will have to remove the lower part of the stock arm by cutting it off to clear the **B&M** lever (See Figure 4). Install the **B&M** selector lever onto the shift shaft of the transmission. Align the selector lever so when it points straight down it travels equal arcs in both directions from the center, then tighten the 1/4"-20 x 1 1/2" pinch bolt and nut. The lever should travel smoothly from front to



**Figure 3**

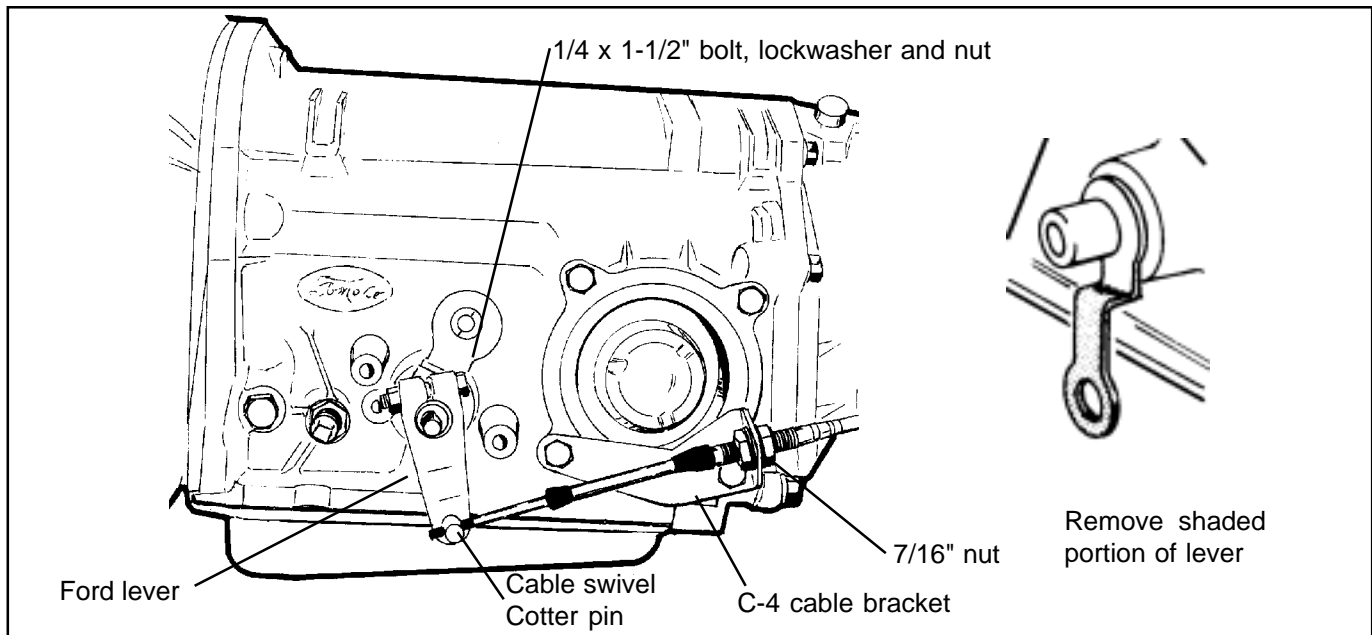

**Figure 4**

back with a positive click in each gear position. Make sure the O-ring is in position on the downshift shaft and install the downshift lever in position on the shaft. Install the lockwasher and nut and tighten securely. The downshift lever must operate smoothly. Reconnect the downshift linkage.

**STEP 15. Cable bracket installation:**

**C-4, C-5:** Remove the two lower bolts from the rear servo cover. Install the cable bracket in position (See Figure 4). Install the two servo cover bolts as removed and tighten to 12-13 lb.ft. Do not overtighten as this can distort the servo cover.

**C-6:** Remove the two transmission oil

pan bolts from the left rear corner of the oil pan. Install the cable bracket in position (See Figure 5) with two spacers between the pan and the bracket. (If your transmission is equipped with a cast aluminum oil pan, these spacers can be omitted.) Install the two 5/16-18 x 1.00" bolts supplied and tighten to 12-13 lb.ft. Do not overtighten as this can damage the pan gasket.

**STEP 16.** Remove the two rubber boots, one large nut, and a large lockwasher from the threaded end of the shifter cable. Route the shifter cable according to Figure 2. Avoid sharp bends and route the cable away from hot engine exhaust

parts. The cable may be secured up and out of the way with nylon cable ties. Slide the end of the cable into the cable bracket, install the lockwasher and the large nut over the end of the cable. Position the cable so the threaded portion of the cable housing is centered in the cable bracket. Tighten both large nuts to hold the cable in this position. Install the two rubber boots onto the end of the cable.

**STEP 17.** Move the transmission selector lever by hand to full rear position (Low). Place the shifter lever to the Low gear position (all the way back). Adjust the large nuts on the cable so that the swivel will slide into the hole on the selector lever. Tighten the large nuts completely. Be sure that the swivel will slide freely in and out of the hole in the selector lever.

With the swivel in the selector lever, move the shifter to the Park position, as far forward as the shifter will go without forcing it. (The shifter has further travel that is used to reach the GM Park position but is not used on Ford transmissions. Trying to force the cable will damage the cable.) The shift lever on the transmission should be all the way forward. Check to see that the swivel will slide freely in and out of the hole in the lever in this position. If it does not slip in freely, adjust the swivel slightly until it will slip into the hole in the lever in both the Low and Park positions. Operate the shifter through all the gear positions. Check to make sure the swivel will slide in and out of the selector lever hole in each gear position. Install the cotter key supplied with the shifter into the swivel and spread the key ends.

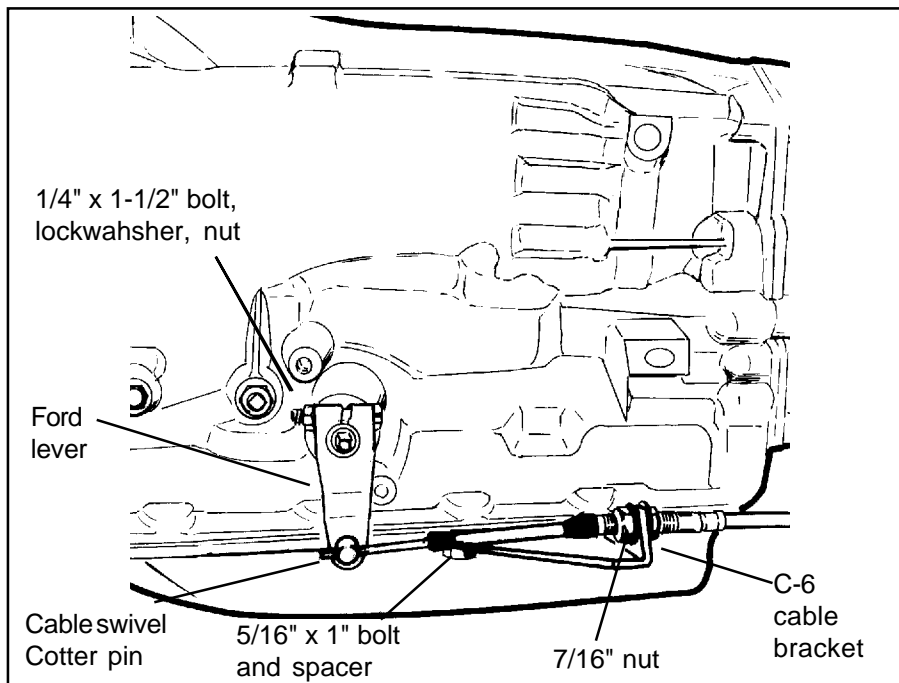

**Figure 6**

If you have a problem, **DO NOT FORCE THE SHIFTER**, this will damage the cable, the shifter or the transmission. Simply start at the beginning and carefully check all your steps.

**STEP 18.** On Ford vehicles, the neutral safety/back-up light switch is located on the transmission (or on the steering column on some early vehicles). On the C-4 and C-5 transmissions it is necessary to completely remove the stock neutral safety/back-up light switch in order to install the **B&M** transmission shift lever. Locate and identify the neutral safety switch (the engine will not crank unless these wires are connected together) and the back-up light switch. Disconnect the battery ground cable before beginning to wire the neutral safety switch. Reroute the wires to the **B&M StarShifter**. Strip 1/4" insulation off the wires and install the supplied slip-on terminals. Crimp the terminals onto the wires using a crimping tool or pliers. Connect the neutral safety wires to the **OUTER** switch on the shifter and the back-up light wires go to the **INNER** switch. Tape the terminal connections to prevent shorts. Reconnect the battery ground cable, disconnect the coil wire and set the parking brake. Check the switch operation by attempting to start the motor in each shifter position. **The starter must crank only when the shifter is in the Park or Neutral position.** The back-up lights should work only in Reverse. Adjust the switches if required. Reconnect the coil wire. Go to **Step 25.**

## CHRYSLER

**STEP 19.** If you have not already done so, loosen the pinch bolt on the throttle lever on the transmission. This is the lever on the small diameter shaft. Pry the lever off with a screwdriver and allow the linkage to hang free. Remove and discard the stock shift lever and the stock shift linkage. Install the **B&M** selector lever in position and tighten the pinch bolt securely (**See Figure 6**). Make sure the lever is not pushed down so far as to touch the transmission case. This will cause the lever to bind on the case. The lever should travel smoothly from front to back with a positive click in each gear position. Install the stock throttle lever in position on the small diameter shaft as removed and tighten the pinch bolt securely. The throttle lever must operate smoothly.

**STEP 20.** Remove the two transmission oil pan bolts directly below the shift lever. Install the cable bracket in position (**See Figure 6**) with two spacers between the pan and the bracket. (If your transmission

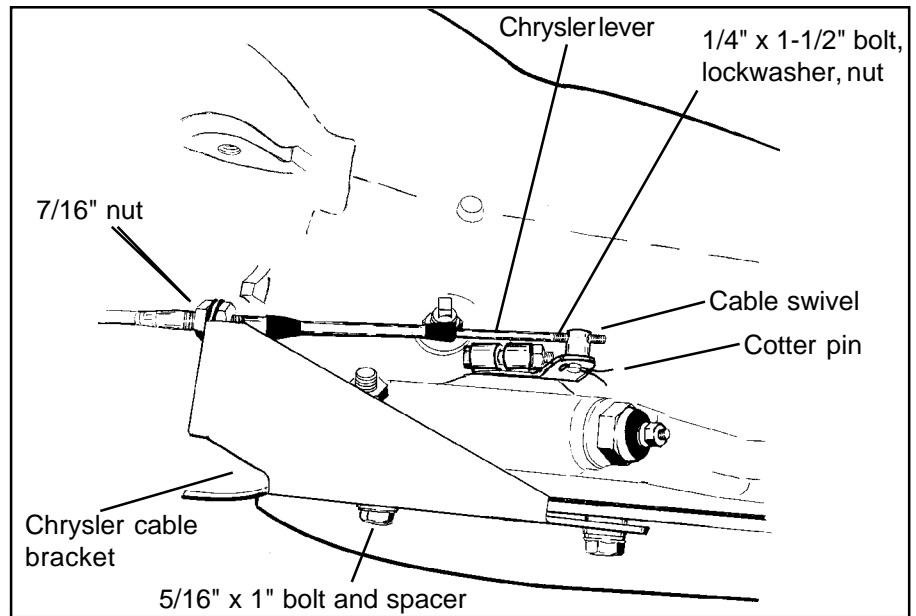

**Figure 6**

is equipped with a cast aluminum oil pan these spacers can be omitted.) Install the two 5/16-18 x 1.00" pan bolts supplied and tighten to 12-13 lb.ft. Do not over-tighten as this can damage the pan gasket.

**STEP 21.** Remove the two rubber boots, one large nut, and a large lockwasher from the threaded end of the shifter cable. Route the shifter cable according to **Figure 2**. Avoid sharp bends and route the cable away from hot engine and exhaust parts. The cable may be secured up out of the way with nylon cable ties. Slide the end of the cable into the cable bracket, install the lockwasher and the large nut over the end of the cable. Position the cable so the threaded portion of the cable housing is centered in the cable bracket. Tighten both large nuts to hold the cable in this position. Install the two rubber boots onto the end of the cable.

**STEP 22.** Move the transmission selector lever by hand to the full forward position (Low). Place the shifter lever to the Low gear position (all the way back). Adjust the large nuts on the cable so that the swivel will slide into the hole on the selector lever. Tighten the large nuts completely. Be sure that the swivel will slide freely in and out of the hole in the selector lever.

With the swivel in the selector lever, move the shifter to the Park position, as far forward as the shifter will go without forcing it. (The shifter has further travel that is used to reach the GM Park position but is not used on Chrysler transmissions. Trying to force the shifter will damage the cable.) The shift lever on the

transmission should be all the way rearward. Check to see that the swivel will slide freely in and out of the hole in the lever in this position. If it does not slip in freely, adjust the swivel slightly until it will slip into the hole in the lever in both the Low and Park positions. Operate the shifter through all the gear positions. Check to make sure the swivel will slide in and out of the selector lever hole in each gear position. Install the cotter key supplied with the shifter into the swivel and spread the key ends.

If you have a problem, **DO NOT FORCE THE SHIFTER**, this will damage the cable, the shifter or the transmission. Simply start at the beginning and carefully check all your steps.

**STEP 23.** Check the operation of the throttle linkage again. The linkage must operate smoothly with no bind. All transmissions using automatic valve bodies must have the throttle linkage connected and operating or transmission damage will result.

**STEP 24.** Neutral Safety/Backup Light switch.

'66-'68: The neutral safety switch will continue to function normally. It will not be necessary to hook up the neutral safety switch wires on the shifter. Disconnect the battery ground cable before wiring the backup light switch. Locate the original backup light switch on the steering column or the console shifter. Run these wires to the **INNER** switch on the shifter (**See Figure 1**). Reconnect the ground wire and check the light for proper operation. Adjust the switches on the shifter if required.

'69 and Later: The neutral safety/backup

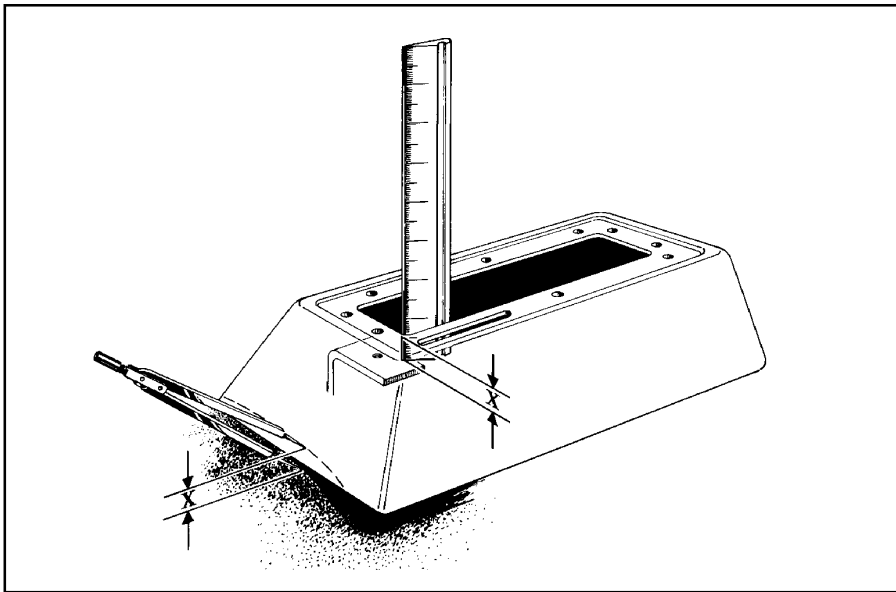

Figure 7

switch is located on the transmission and will continue to function normally. It will not be necessary to connect any wires to the switches on the shifter.

**STEP 25.** Place the black tower over shifter mechanism until the bottom edge of the tower touches the floor. Hold the tower level to the shifter with the bottom of the tower touching the highest surface on the floor it will come into contact with (See Figure 7). Use a ruler to measure the distance X from the underside of the tower to the tower mounting brackets on the shifter mechanism.

**STEP 26.** Set a pair of dividers at the distance X, measured in step 25. Hold the tower level to the shifter mechanism with the bottom of the tower touching the highest surface on the floor it will come into contact with. Holding the tower in position, place one leg of the divider against the floor while the other touches the tower

(See Figure 7). Using the dividers, scribe a line around the tower that follows the contour of the floorboard. Remove the tower and trim at the scribe line using tin snips.

**STEP 27.** Install the chrome boot cover plate in position over the boot. Install the seven cover plate/tower self tapping screws through the plate, boot and tower (See Figure 8). Do not install the screws in locations A and B at this time. Do not overtighten or you will distort the cover plate.

**STEP 28.** Apply the StarShifter decal to the plate on the shifter stick (See Figure 9). Install the boot/tower assembly in place over the shifter mechanism. Slip the boot over the plate on the shifter stick so the plate fits into the grooves inside of the boot. Align the tower and install the two self-tapping screws into locations A and B (See Figure 8). Tighten the screws

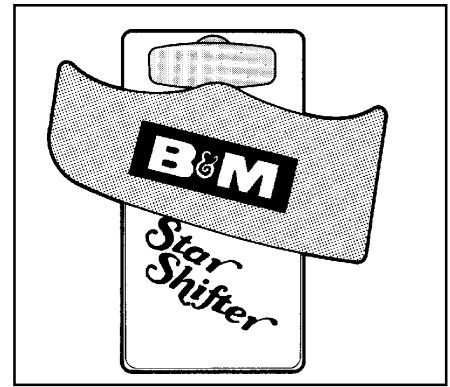

Figure 9

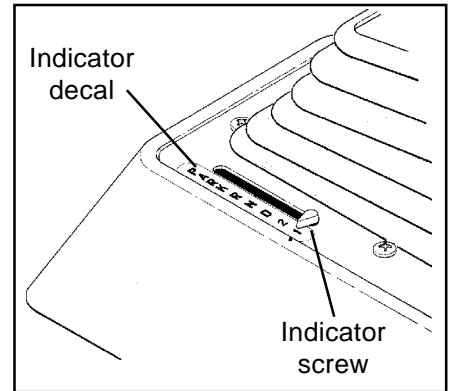

Figure 10

snugly. Do not overtighten or you will distort the cover plate. Install the T-handle and the jam nut. Position the T-handle so it is comfortable and tighten the jam nut to secure the handle in place.

**STEP 29.** Install the indicator screw through the slot in the boot cover plate and thread into the plastic traveler under the slot. Tighten until snug and align so it is pointing away from the boot and the square with the slot (See Figure 10). Place the Shifter in first (Low gear position). To find the first gear, lift the trigger and pull the lever all the way back. The lever will stop in first gear. The indicator screw will be at the back of the slot. You must be sure that the stick is all the way back (forward pressure on stick will move shifter out of first gear). Position the indicator decal left of the indicator screw on the chrome boot cover plate. Align 1 on the indicator decal with the indicator screw and press tape in place (See Figure 9). (Note the indicator tape is not centered with the slot.)

#### OPERATION

The B&M StarShifter combines a vertical gate shifter and a ratchet shifter in one mechanism. Refer to the following instructions for proper operation:

**Vertical gate mode:** In the forward position the shifter functions in the vertical

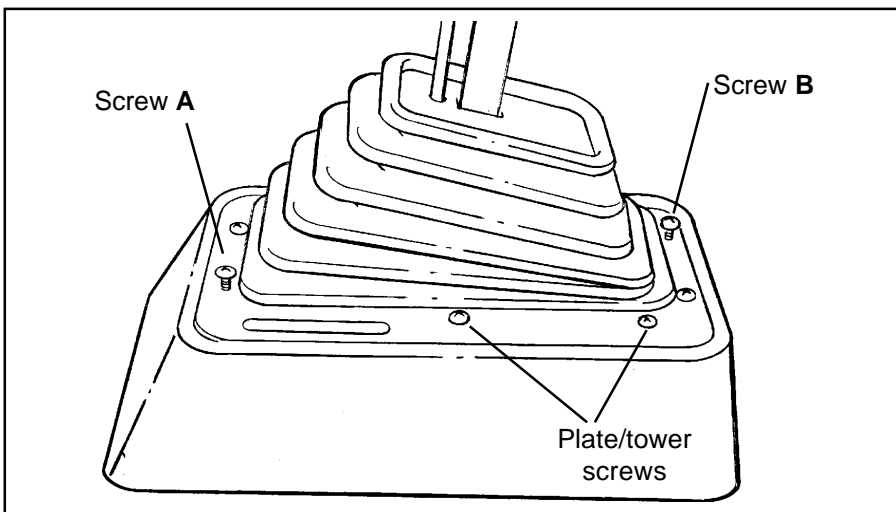

Figure 8

gate mode. The stick travels in a direct line forward and backwards. The trigger handle must be raised to clear the stops when going through the gear positions (See Figure 11).

**Park:** To get Park from any vertical gate gear position, push the stick to the Neutral position, raise the trigger all the way and push the stick all the way forward to the Park position. Release the trigger and the shifter is locked in Park. To get to any other gear position you must raise the trigger handle to clear the stops.

**Reverse:** Raise the trigger handle to clear the stop and move the stick to the Reverse position.

**Neutral:** Move the stick to Neutral. You do not have to raise the trigger unless you are in Park.

**Drive (3rd):** Move the stick to Drive. You do not have to raise the trigger unless you are in Park. The stick can be moved between Neutral and Drive without using the trigger.

**Second:** Raise the trigger to clear the stop and move the lever to the second gear position.

**First:** Raise the trigger handle further to

clear the stop and shift into first.

**Ratchet Shift Mode:** The ratchet shift mode allows firm, positive, no-miss upshifts from First to Second and Second to Third. It is impossible to miss a gear, overshift or accidentally downshift the transmission in the ratchet shift mode. To shift from vertical gate to ratchet shift operation, move the stick to the First gear position. Raise the trigger and pull the stick all the way back until it stops. Then release the trigger. The shifter is now in first gear of the ratchet shift mode (See Figure 12).

**1-2 Upshift:** Push the stick forward with a quick firm push until it hits the internal stop. Do not lift the trigger. Release the stick and allow the spring to return it to the rear position. The transmission is now in the second gear position, ready for the 2-3 upshift (See Figure 13).

**2-3 Upshift:** Push the stick forward again with a quick firm push until it hits an internal stop. Release the stick and allow it to return to the rear position. The transmission is now in Third (Drive) position.

Once the shifter is in the Drive (Third) position the stick is disconnected from

the shifter mechanism to prevent accidental Neutral or Reverse engagement.

To switch the shifter back from ratchet to vertical gate operation once you are in Drive, lift the trigger and move the stick forward. Hold the trigger up until a forward stop is felt. Release the trigger. You are now in Drive position in the vertical gate mode (See Figure 14). Note: If you want to go directly from Drive to Neutral while switching from ratchet to vertical gate mode, follow the same procedure as above except release the trigger as soon as you move the stick forward. If this is done the stick will continue through Drive into Neutral.

**Remember:** To go from vertical gate mode into ratchet shift mode the shifter must be put into the Low gear position. To shift from Ratchet shift mode into vertical gate mode the shifter must be put in the Drive position.

If these instructions for operating the shifter seem complicated, do not be alarmed. You will find that, in actual use, the shifter will be extremely easy to operate after a minimal amount of experience. (See Figures 12, 13 and 14.)

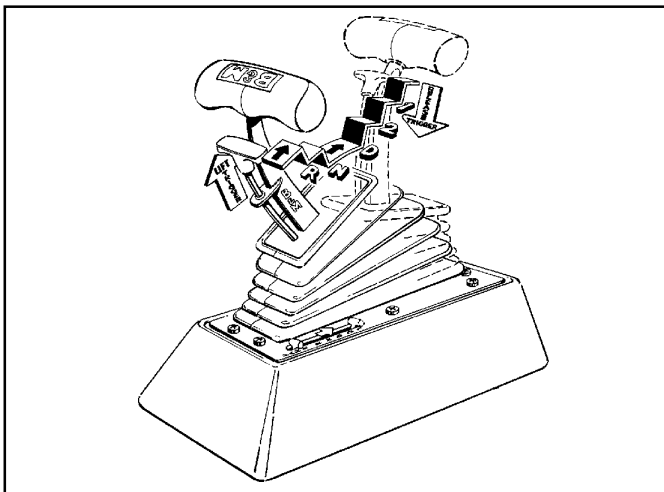

Figure 11

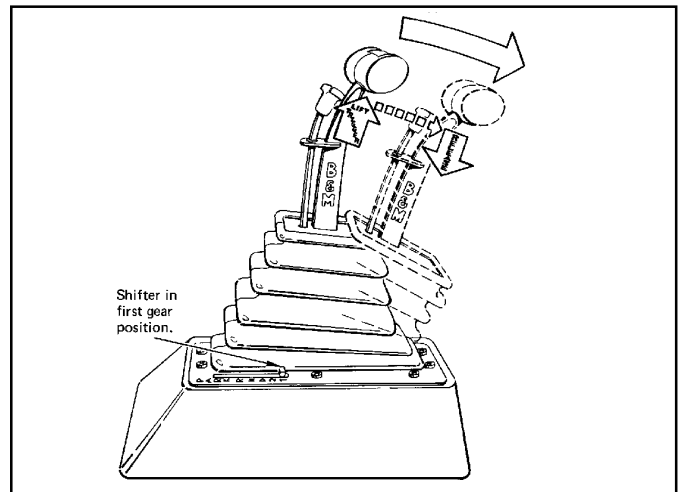

Figure 12

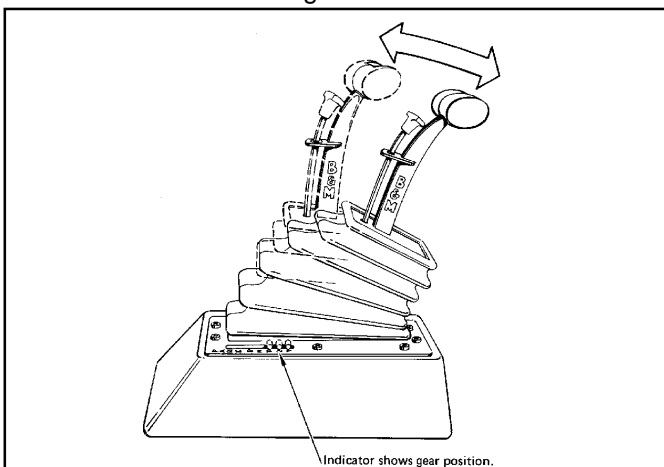

Figure 13

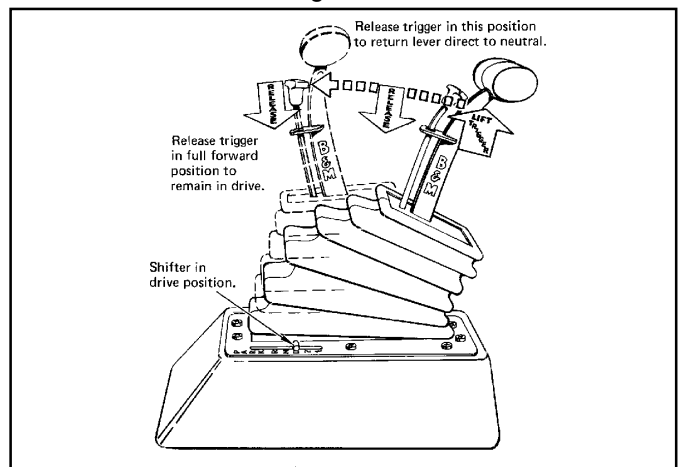

Figure 14

### TOOL LIST

- 1 Phillips screwdriver
- 1 7/16 socket
- 1 Ratchet or speed handle
- 1 7/16" wrench
- 1 1/2" wrench
- 1 9/16" wrench
- 2 11/16 wrench
- 1 9/32 drill bit
- 1 drill motor
- 1 1-1/2" holesaw
- 1 Crimping tool
- 1 Torque wrench 0-50 ft.lbs.
- 1 File
- 1 Tin snips
- 1 Wire strippers
- 1 Ruler
- 1 Dividers
- 1 Electrical tape
- 1 Hacksaw
- 1 Hammer
- 1 Drift pin
- 2-4 Jackstands
- A/R Cable ties

### CHECK LIST

- \_\_\_ Locking steering column lever is permanently fastened in the full up position. Step 1.
- \_\_\_ Shifter is convenient to reach and has ample room for your hand in both park and low gear. Step 2.
- \_\_\_ Carpet covers floorboard holes. Step 4.
- \_\_\_ Cable is securely fastened to the shifter and held with E-clip. Step 5.
- \_\_\_ Shifter is securely mounted to floorboard. Step 7.
- \_\_\_ Shifter cable is clear of exhaust system, engine and any moving parts. Step 7.
- \_\_\_ Throttle lever and shift lever are tight on transmission. GM step 9, Ford Step 14, Chrysler Step 20.
- \_\_\_ Oil pan bolts are tightened to 12-13 lb.ft. GM Step 10, Ford Step 16, Chrysler Step 21.
- \_\_\_ Shifter is properly adjusted. Cable boots are installed, cable nuts are tightened and swivel is secured with cotter key. GM Step 11, Ford Step 17, Chrysler Step 22.
- \_\_\_ The Neutral safety switch is connected and properly adjusted to prevent engine starts in drive gears and reverse. GM Step 12, Ford Step 18, Chry not required.
- \_\_\_ There is no debris in the shifter mechanism.
- \_\_\_ Tower is trimmed. Step 26.
- \_\_\_ Boot and tower effectively cover mechanism. Step 27.
- \_\_\_ Indicator screw indicated gear properly. Step 29.
- \_\_\_ Shifter moves freely in all positions as described in Shifter Operation.
- \_\_\_ If your shifter is not working properly do not attempt to drive your car. Make sure you have followed all instructions. If the shifter is broken or defective return it to your **B&M** dealer.

### IMPORTANT

Before installing the knob onto the shifter put Loctite on the threads of the stick. The knob may gall on the threads of the stick and make it impossible to remove the knob from the stick. If this occurs it can cause the stick to break if you use excessive force while attempting to remove the knob from the stick.

### WARNING

PERIODIC INSPECTION AND MAINTENANCE OF YOUR SHIFTER IS RECOMMENDED TO ENSURE THAT THE MECHANISM IS WELL LUBRICATED, FREE FROM DIRT OR RUST AND THAT THE CABLE IS PROPERLY ADJUSTED. LACK OF MAINTENANCE COULD RESULT IN A FAILURE INCLUDING A FAILURE OF THE REVERSE LOCKOUT SAFETY FEATURE.

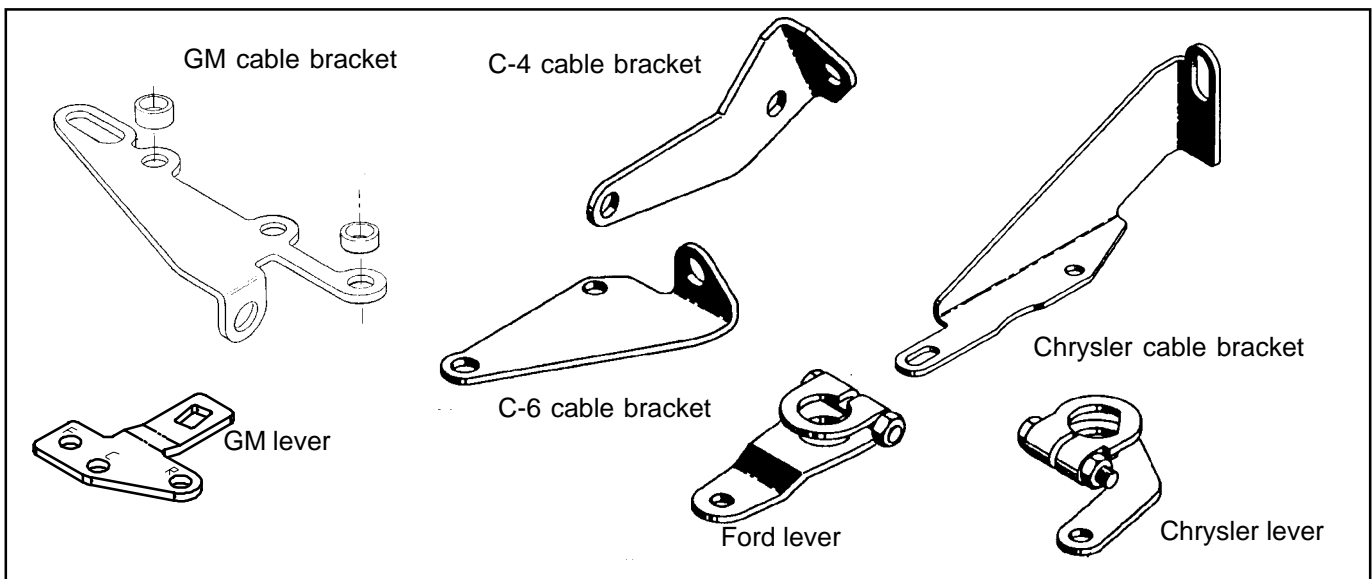

Cable brackets and levers